



## European Technical Approval ETA-11/0080

*English translation prepared by DIBt - Original version in German language*

Handelsbezeichnung <i>Trade name</i>	Simpson Strong-Tie® - Bolzenanker WA Simpson Strong-Tie® - Throughbolt WA
Zulassungsinhaber <i>Holder of approval</i>	Simpson Strong-Tie Ireland Ltd. ZNL - Deutschland Werner-von-Siemens-Straße 35 64319 Pfungstadt DEUTSCHLAND
Zulassungsgegenstand und Verwendungszweck <i>Generic type and use of construction product</i>	Kraftkontrolliert spreizender Dübel aus verzinktem Stahl in den Größen M6, M8, M10, M12 und M16 zur Verankerung im ungerissenen Beton <i>Torque controlled expansion anchor made of zinc coated steel of sizes M6, M8, M 10, M 12 and M 16 for use in non-cracked concrete</i>
Geltungsdauer: <i>Validity:</i>	vom <i>from</i> bis <i>to</i>
Herstellwerk <i>Manufacturing plant</i>	Simpson Strong-Tie Manufacturing Facilities

Diese Zulassung umfasst  
*This Approval contains*

12 Seiten einschließlich 5 Anhänge  
*12 pages including 5 annexes*

## I LEGAL BASES AND GENERAL CONDITIONS

- 1 This European technical approval is issued by Deutsches Institut für Bautechnik in accordance with:
  - Council Directive 89/106/EEC of 21 December 1988 on the approximation of laws, regulations and administrative provisions of Member States relating to construction products<sup>1</sup>, modified by Council Directive 93/68/EEC<sup>2</sup> and Regulation (EC) N° 1882/2003 of the European Parliament and of the Council<sup>3</sup>;
  - Gesetz über das In-Verkehr-Bringen von und den freien Warenverkehr mit Bauprodukten zur Umsetzung der Richtlinie 89/106/EWG des Rates vom 21. Dezember 1988 zur Angleichung der Rechts- und Verwaltungsvorschriften der Mitgliedstaaten über Bauprodukte und anderer Rechtsakte der Europäischen Gemeinschaften (Bauproduktengesetz - BauPG) vom 28. April 1998<sup>4</sup>, as amended by law of 31 October 2006<sup>5</sup>;
  - Common Procedural Rules for Requesting, Preparing and the Granting of European technical approvals set out in the Annex to Commission Decision 94/23/EC<sup>6</sup>;
  - Guideline for European technical approval of "Metal anchors for use in concrete - Part 2: Torque controlled expansion anchors ", ETAG 001-02.
- 2 Deutsches Institut für Bautechnik is authorized to check whether the provisions of this European technical approval are met. Checking may take place in the manufacturing plant. Nevertheless, the responsibility for the conformity of the products to the European technical approval and for their fitness for the intended use remains with the holder of the European technical approval.
- 3 This European technical approval is not to be transferred to manufacturers or agents of manufacturers other than those indicated on page 1, or manufacturing plants other than those indicated on page 1 of this European technical approval.
- 4 This European technical approval may be withdrawn by Deutsches Institut für Bautechnik, in particular pursuant to information by the Commission according to Article 5(1) of Council Directive 89/106/EEC.
- 5 Reproduction of this European technical approval including transmission by electronic means shall be in full. However, partial reproduction can be made with the written consent of Deutsches Institut für Bautechnik. In this case partial reproduction has to be designated as such. Texts and drawings of advertising brochures shall not contradict or misuse the European technical approval.
- 6 The European technical approval is issued by the approval body in its official language. This version corresponds fully to the version circulated within EOTA. Translations into other languages have to be designated as such.

<sup>1</sup> Official Journal of the European Communities L 40, 11 February 1989, p. 12  
<sup>2</sup> Official Journal of the European Communities L 220, 30 August 1993, p. 1  
<sup>3</sup> Official Journal of the European Union L 284, 31 October 2003, p. 25  
<sup>4</sup> *Bundesgesetzblatt Teil I 1998*, p. 812  
<sup>5</sup> *Bundesgesetzblatt Teil I 2006*, p. 2407, 2416  
<sup>6</sup> Official Journal of the European Communities L 17, 20 January 1994, p. 34

## II SPECIFIC CONDITIONS OF THE EUROPEAN TECHNICAL APPROVAL

### 1 Definition of product and intended use

#### 1.1 Definition of the construction product

The Simpson Strong-Tie® Throughbolt WA of sizes 6-40, 8-45, 10-50, 12-65 and 16-80 is an anchor made of galvanised steel which is placed into a drilled hole and anchored by torque-controlled expansion.

An illustration of the product and intended use is given in Annex 1.

#### 1.2 Intended use

The anchor is intended to be used for anchorages for which requirements for mechanical resistance and stability and safety in use in the sense of the Essential Requirements 1 and 4 of Council Directive 89/106 EEC shall be fulfilled and failure of anchorages made with these products would cause risk to human life and/or lead to considerable economic consequences. The anchor is to be used only for anchorages subject to static or quasi-static loading in reinforced or unreinforced normal weight concrete of strength classes C20/25 at minimum and C50/60 at most according to EN 206:2000-12.

It may be anchored in non-cracked concrete only.

The anchor may only be used in structures subject to dry internal conditions.

The provisions made in this European technical approval are based on an assumed working life of the anchor of 50 years. The indications given on the working life cannot be interpreted as a guarantee given by the producer, but are to be regarded only as a means for choosing the right products in relation to the expected economically reasonable working life of the works.

### 2 Characteristics of the product and methods of verification

#### 2.1 Characteristics of the product

The anchor corresponds to the drawings and provisions given in Annex 2. The characteristic material values, dimensions and tolerances of the anchor not given in Annex 2 shall correspond to the respective values laid down in the technical documentation<sup>7</sup> of this European technical approval.

The characteristic values for the design of anchorages are given in Annexes 4 and 5.

Each anchor is marked with the identifying mark, the commercial name, the bolt diameter and effective anchorage depth according to Annex 1.

The anchor shall only be packaged and supplied as a complete unit.

#### 2.2 Methods of verification

The assessment of fitness of the anchor for the intended use in relation to the requirements for mechanical resistance and stability and safety in use in the sense of the Essential Requirements 1 and 4 has been made in accordance with the "Guideline for European technical approval of Metal Anchors for Use in Concrete", Part 1 "Anchors in general" and Part 2 "Torque-controlled expansion anchors", on the basis of Option 7.

<sup>7</sup> The technical documentation of this European technical approval is deposited at the Deutsches Institut für Bautechnik and, as far as relevant for the tasks of the approved bodies involved in the attestation of conformity procedure, is handed over to the approved bodies.

In addition to the specific clauses relating to dangerous substances contained in this European technical approval, there may be other requirements applicable to the products falling within its scope (e.g. transposed European legislation and national laws, regulations and administrative provisions). In order to meet the provisions of the Construction Products Directive, these requirements need also to be complied with, when and where they apply.

### 3 Evaluation and attestation of conformity and CE marking

#### 3.1 System of attestation of conformity

According to the Decision 96/582/EG of the European Commission<sup>8</sup> system 2(i) (referred to as system 1) of the attestation of conformity applies.

This system of attestation of conformity is defined as follows:

System 1: Certification of the conformity of the product by an approved certification body on the basis of:

- (a) Tasks for the manufacturer:
  - (1) factory production control;
  - (2) further testing of samples taken at the factory by the manufacturer in accordance with a prescribed control plan;
- (b) Tasks for the approved body:
  - (3) initial type-testing of the product;
  - (4) initial inspection of factory and of factory production control;
  - (5) continuous surveillance, assessment and approval of factory production control.

Note: Approved bodies are also referred to as "notified bodies".

#### 3.2 Responsibilities

##### 3.2.1 Tasks for the manufacturer

###### 3.2.1.1 Factory production control

The manufacturer shall exercise permanent internal control of production. All the elements, requirements and provisions adopted by the manufacturer shall be documented in a systematic manner in the form of written policies and procedures, including records of results performed. This production control system shall insure that the product is in conformity with this European technical approval.

The manufacturer may only use initial / raw / constituent materials stated in the technical documentation of this European technical approval.

The factory production control shall be in accordance with the control plan which is part of the technical documentation of this European technical approval. The control plan is laid down in the context of the factory production control system operated by the manufacturer and deposited with Deutsches Institut für Bautechnik.<sup>9</sup>

The results of factory production control shall be recorded and evaluated in accordance with the provisions of the control plan.

<sup>8</sup> Official Journal of the European Communities L 254 of 08.10.1996

<sup>9</sup> The control plan is a confidential part of the European technical approval and only handed over to the approved body involved in the procedure of attestation of conformity. See section 3.2.2.

#### 3.2.1.2 Other tasks of manufacturer

The manufacturer shall, on the basis of a contract, involve a body which is approved for the tasks referred to in section 3.1 in the field of in order to undertake the actions laid down in section 3.2.2 For this purpose, the control plan referred to in sections 3.2.1.1 and 3.2.2 shall be handed over by the manufacturer to the approved body involved.

The manufacturer shall make a declaration of conformity, stating that the construction product is in conformity with the provisions of this European technical approval.

#### 3.2.2 Tasks for the approved bodies

The approved body shall perform the

- initial type-testing of the product,
- initial inspection of factory and of factory production control,
- continuous surveillance, assessment and approval of factory production control,

in accordance with the provisions laid down in the control plan.

The approved body shall retain the essential points of its actions referred to above and state the results obtained and conclusions drawn in a written report.

The approved certification body involved by the manufacturer shall issue an EC certificate of conformity of the product stating the conformity with the provisions of this European technical approval.

In cases where the provisions of the European technical approval and its control plan are no longer fulfilled the certification body shall withdraw the certificate of conformity and inform Deutsches Institut für Bautechnik without delay.

#### 3.3 CE marking

The CE marking shall be affixed on each packaging of the anchor. The letters "CE" shall be followed by the identification number of the approved certification body, where relevant, and be accompanied by the following additional information:

- the name and address of the Producer (legal entity responsible for the manufacturer),
- the last two digits of the year in which the CE marking was affixed,
- the number of the EC certificate of conformity for the product,
- the number of the European technical approval,
- the number of the guideline for European technical approval
- use category (ETAG 001-1 Option 7),
- size.

#### **4 Assumptions under which the fitness of the product for the intended use was favourably assessed**

##### **4.1 Manufacturing**

The European technical approval is issued for the product on the basis of agreed data/information, deposited with the Deutsches Institut für Bautechnik, which identifies the product that has been assessed and judged. Changes to the product or production process, which could result in this deposited data/information being incorrect, should be notified to the Deutsches Institut für Bautechnik before the changes are introduced. Deutsches Institut für Bautechnik will decide whether or not such changes affect the approval and consequently the validity of the CE marking on the basis of the approval and if so whether further assessment or alterations to the approval shall be necessary.

##### **4.2 Design of anchorages**

The fitness of the anchor for the intended use is given under the following conditions:

The anchorages are designed in accordance with the "Guideline for European technical approval of Metal Anchors for Use in Concrete", Annex C, Method A, under the responsibility of an engineer experienced in anchorages and concrete work.

Verifiable calculation notes and drawings are taking account of the loads to be anchored.

The position of the anchor is indicated on the design drawings (e.g. position of the anchor relative to reinforcement or to supports).

##### **4.3 Installation of anchors**

The fitness for use of the anchor can only be assumed if the anchor is installed as follows:

- Anchor installation carried out by appropriately qualified personnel and under the supervision of the person responsible for technical matters of the site,
- Use of the anchor only as supplied by the manufacturer without exchanging the components of an anchor,
- Anchor installation in accordance with the manufacturer's specifications and drawings and using the appropriate tools,
- Checks before placing the anchor to ensure that the strength class of the concrete in which the anchor is to be placed is in the range given and is not lower than that of the concrete to which the characteristic loads apply,
- Check of concrete being well compacted, e.g. without significant voids,
- Edge distances and spacing not less than the specified values without minus tolerances,
- Drilling technique by hammer drilling only,
- Positioning of the drill holes without damaging the reinforcement,
- In case of aborted hole: new drilling at a minimum distance away of twice the depth of the aborted hole or smaller distance if the aborted drill hole is filled with high strength mortar and if under shear or oblique tension load it is not in the direction of load application,
- Cleaning of the hole of drilling dust and anchor installation in accordance with Annex 3,
- Keeping the effective anchorage depth,
- Application of the torque moment  $T_{inst}$  given in Annex 3 using a calibrated torque wrench.

## 5 Responsibility of the manufacturer

The manufacturer is responsible to ensure that the information on the specific conditions according to 1 and 2 including Annexes referred to as well as sections 4.2 and 4.3 is given to those who are concerned. This information may be made by reproduction of the respective parts of the European technical approval. In addition all installation data shall be shown clearly on the package and/or on an enclosed instruction sheet, preferably using illustration(s).

The minimum data required are:

- Diameter of drill bit,
- Thread diameter,
- Maximum thickness of the fixture,
- Minimum effective anchorage depth,
- Minimum hole depth,
- Torque moment,
- Information on the installation procedure, including cleaning of the hole, preferably by means of an illustration,
- Reference to any special installation equipment needed,
- Identification of the manufacturing batch.

Georg Feistel  
Head of Department

*beglaubigt:*  
Baderschneider

## Simpson Strong-Tie® Throughbolt WA

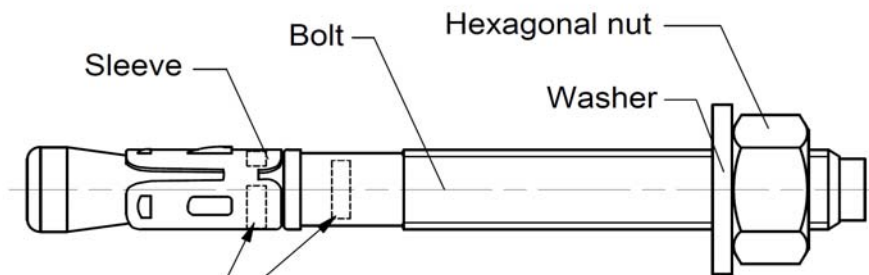

### Marking

<u>Sleeve:</u>	Identifying mark: Commercial name: Size:	≠ WA M .... (M12)
<u>Bolt:</u>	Diameter - Eff. anchorage depth:	12 - 65

### Throughbolt WA after installation

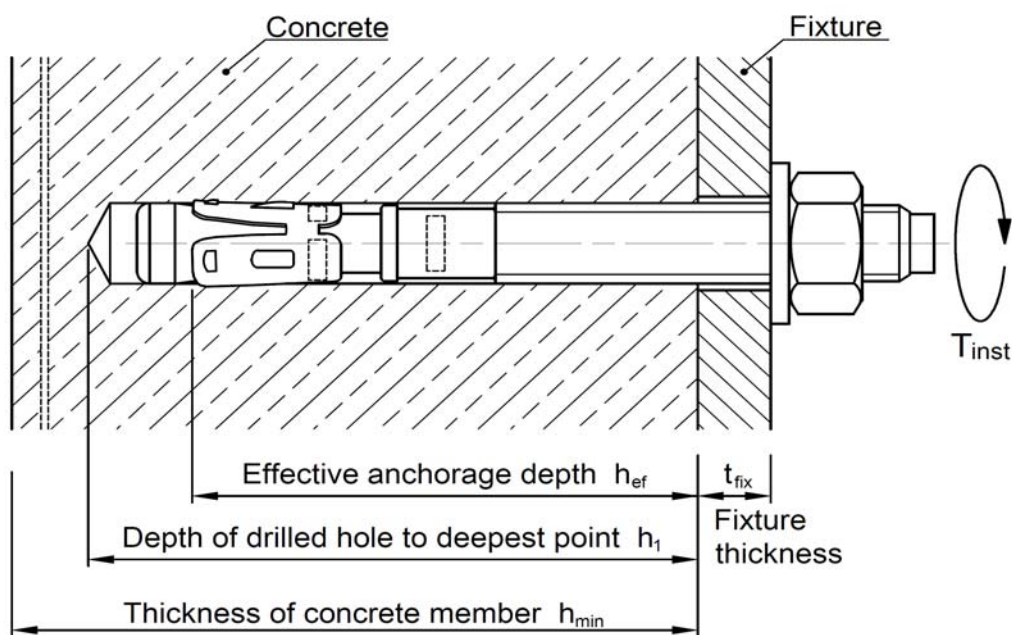

**Simpson Strong-Tie®  
Throughbolt WA**

**Product and intended use**

**Annex 1**

of European  
technical approval  
**ETA-11/0080**

## Simpson Strong-Tie® Throughbolt WA

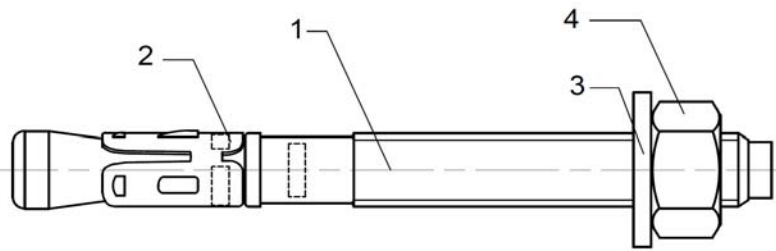

**Table 1: Materials**

Part	Designation	Material <sup>1)</sup>
1	Bolt	Carbon steel, cold formed
2	Sleeve	Carbon steel strip, cold formed
3	Washer	Steel; DIN 125 (EN ISO 7089), DIN 440 (EN ISO 7094) DIN 9021 (EN ISO 7093)
4	Hexagonal nut	Steel DIN 934 (EN ISO 4032), property class 8 acc. EN 20898-2

<sup>1)</sup> zinc electroplated  $\geq 5 \mu\text{m}$  according EN ISO 4042; passivated

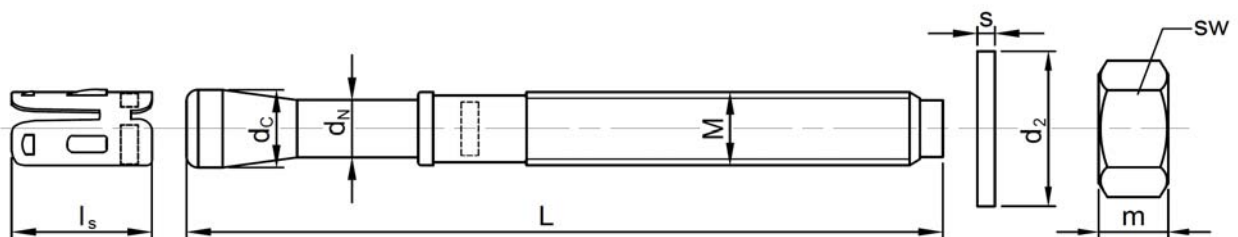

**Table 2: Dimensions**

Anchor size	Bolt				Sleeve $l_s$ [mm]	Washer		Hex-nut	
	L [mm]	M	$d_C$ [mm]	$d_N$ [mm]		s [mm]	$d_2$ [mm]	m [mm]	SW [mm]
<b>M6</b>	$t_{fix} + 55$	M6	6.00	4.3	12.5	1.6	$\geq 12$	5.0	10
<b>M8</b>	$t_{fix} + 63$	M8	8.00	5.9	15.0	1.6	$\geq 16$	6.5	13
<b>M10</b>	$t_{fix} + 73$	M10	10.00	7.6	16.8	2.0	$\geq 20$	8.0	17
<b>M12</b>	$t_{fix} + 99$	M12	11.95	8.8	20.0	2.5	$\geq 24$	10.0	19
<b>M16</b>	$t_{fix} + 121$	M16	15.95	12.0	22.6	3.0	$\geq 30$	13.0	24

**Simpson Strong-Tie®  
Throughbolt WA**

**Materials and dimensions**

**Annex 2**

of European  
technical approval  
**ETA-11/0080**

**Table 3: Installation data**

Simpson Strong-Tie® Throughbolt WA			Anchor size				
			M6	M8	M10	M12	M16
Max. total length	L	[mm]	120	165	220	260	260
Drill hole diameter	d <sub>o</sub>	[mm]	6	8	10	12	16
Cutting diameter at the upper tolerance limit (max. diameter drill bit)	d <sub>cut,max</sub> ≤	[mm]	6.45	8.45	10.45	12.50	16.50
Effective anchorage depth	h <sub>ef</sub>	[mm]	40	45	50	65	80
Depth of drilled hole to deepest point	h <sub>1</sub> ≥	[mm]	55	65	70	90	110
Diameter of clearance hole in the fixture	d <sub>f</sub> ≤	[mm]	7	9	12	14	18
Maximum thickness of fixture	t <sub>fix,max</sub>	[mm]	65	100	140	160	140
Installation torque	T <sub>inst</sub>	[Nm]	8	15	30	50	100
Width across flats	SW	[mm]	10	13	17	19	24
Minimum thickness of concrete member	h <sub>min</sub>	[mm]	100	100	100	130	160
Minimum allowable spacing	s <sub>min</sub>	[mm]	30	40	50	70	90
Minimum allowable edge distance	c <sub>min</sub>	[mm]	40	40	50	70	90

**Installation instruction**

1. Drill hole

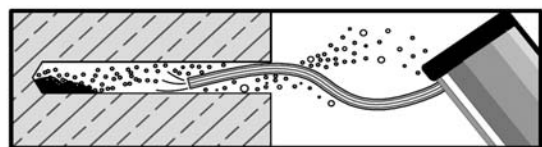

2. Clean hole

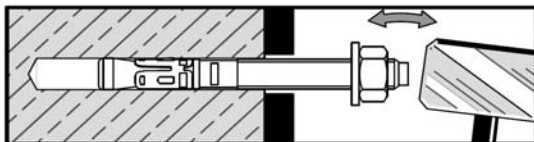

3. Insert the anchor through the fixture

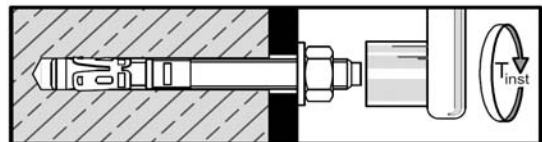
4. Apply installation torque T<sub>inst</sub> using a calibrated torque-wrench

**Simpson Strong-Tie®  
Throughbolt WA**

Installation data

**Annex 3**

of European  
technical approval  
**ETA-11/0080**

**Table 4: Characteristic values of resistance to tension loads.  
Design method A**

Simpson Strong-Tie® Throughbolt WA			Anchor size				
			M6	M8	M10	M12	M16
<b>Steel failure</b>							
Characteristic resistance	$N_{Rk,s}$	[kN]	10.9	20.5	32.3	45.6	79.2
Partial safety factor	$\gamma_{Ms}$	[-]	1.4 <sup>1)</sup>				
<b>Pull-out failure</b>							
Characteristic resistance in non-cracked concrete C20/25	$N_{Rk,p}$	[kN]	9	12	16	3)	3)
Increasing factor for $N_{Rk,p}$	$\Psi_C$	C30/37	1.08	1.22		-	-
		C40/50	1.16	1.41			
		C50/60	1.23	1.55			
Partial safety factor	$\gamma_{Mp}$	[-]	1.5 <sup>1)2)</sup>				
<b>Concrete cone failure and splitting failure</b>							
Effective anchorage depth	$h_{ef}$	[mm]	40	45	50	65	80
Spacing	$s_{cr,N}$	[mm]	3 x $h_{ef}$				
Edge distance	$c_{cr,N}$	[mm]	1.5 x $h_{ef}$				
Spacing (splitting)	$s_{cr,sp}$	[mm]	2 x $c_{cr,sp}$				
Edge distance (splitting)	$c_{cr,sp}$	[mm]	80	115	125	180	200
Partial safety factor	$\gamma_{Mc} = \gamma_{Msp}$	[-]	1.5 <sup>1)2)</sup>				

1) In absence of other national regulations.

2) The partial safety factor  $\gamma_2 = 1.0$  included.

3) Pull-out failure mode is not decisive.

**Table 5: Displacements under tension loads**

Simpson Strong-Tie® Throughbolt WA			Anchor size				
			M6	M8	M10	M12	M16
Tension load in non-cracked concrete C20/25	N	[kN]	4.3	5.7	7.6	12.6	17.2
Displacement	$\delta_{N0}$	[mm]	0.2	0.4	0.2	0.2	0.2
	$\delta_{N\infty}$	[mm]	1.1	1.1	1.1	1.1	1.1

**Simpson Strong-Tie®  
Throughbolt WA**

**Design method A:  
Char. values of resistance to tension loads / Displacements**

**Annex 4**

of European  
technical approval  
**ETA-11/0080**

**Table 6: Characteristic values of resistance to shear loads.  
Design method A**

Simpson Strong-Tie® Throughbolt WA			Anchor size				
			M6	M8	M10	M12	M16
<b>Steel failure without lever arm</b>							
Characteristic resistance	$V_{Rk,s}$	[kN]	6	9.5	17	25	47
Partial safety factor	$\gamma_{Ms}$	[-]	1.25 <sup>1)</sup>				
<b>Steel failure with lever arm</b>							
Characteristic resistance	$M_{Rk,s}^0$	[Nm]	12	29	57	99	233
Partial safety factor	$\gamma_{Ms}$	[-]	1.25 <sup>1)</sup>				
<b>Concrete pry-out failure</b>							
Factor in equation ( 5.6 ) of ETAG 001 Annex C, 5.2.3.3	k	[-]	1			2	
Partial safety factor	$\gamma_{Mc}$	[-]	1.5 <sup>1)</sup>				
<b>Concrete edge failure</b>							
Effective length of anchor under shear loading	$l_f$	[mm]	40	45	50	65	80
Outside diameter of anchor	$d_{nom}$	[mm]	6	8	10	12	16
Partial safety factor	$\gamma_{Mc}$	[-]	1.5 <sup>1)2)</sup>				

1) In absence of other national regulations.

2) The partial safety factor  $\gamma_2 = 1.0$  included.

**Table 7: Displacements under shear loads**

Simpson Strong-Tie® Throughbolt WA			Anchor size				
			M6	M8	M10	M12	M16
Shear load	V	[kN]	3.4	5.4	9.7	14.3	26.9
Displacement	$\delta_{V0}$	[mm]	1.1	1.5	5.1	2.1	3.0
	$\delta_{V\infty}$	[mm]	1.7	2.2	7.7	3.2	4.6

**Simpson Strong-Tie®  
Throughbolt WA**

**Design method A:**

**Char. values of resistance to shear loads / Displacements**

**Annex 5**

of European  
technical approval  
**ETA-11/0080**