

# Centre Scientifique et Technique du Bâtiment

84 avenue Jean Jaurès  
Champs sur Marne  
F-77447 Marne-la-Vallée Cedex 2  
Tél. : (33) 01 64 68 82 82  
Fax : (33) 01 60 05 70 37

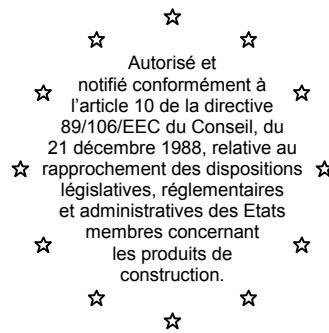

**CSTB**  
le futur en construction

**MEMBRE DE L'EOTA**

## European Technical Approval

## ETA-05/0013

(English language translation, the original version is in French language)

Nom commercial :

**Trade name:**

**Simpson Strong-Tie®**

**LIEBIG Superplus™ A4 self- undercutting anchor**

Titulaire :

**Holder of approval:**

**SIMPSON Strong-Tie Ireland Ltd.**

**ZNL - Deutschland**

**Werner-von-Siemens-Str.35**

**64319 Pfungstadt**

**DEUTSCHLAND**

Type générique et utilisation prévue du produit de construction :

Cheville métallique autoverouillante en acier inoxydable, à expansion par vissage à couple contrôlé, de fixation dans le béton fissuré ou non fissuré : diamètres M8, M12 et M16.

**Generic type and use of construction product:**

**Torque-controlled self undercutting anchor, made of stainless steel, for use in cracked or non-cracked concrete: sizes M8, M12 and M16.**

Validité du :  
au :

**01/03/2010**

**01/03/2015**

**Validity from / to:**

Usine de fabrication :

**Manufacturing plant:**

Simpson Strong-Tie Manufacturing Facilities

Le présent Agrément technique européen contient :

18 pages incluant 11 annexes faisant partie intégrante du document.

**This European Technical Approval contains:**

**18 pages including 11 annexes which form an integral part of the document.**

Cet agrément Technique Européen annule et remplace l'ATE ETA-05/0013 valide du 01/03/2005 au 01/03/2010

**This European Technical Approval cancels and replaces ETA-05/0013 with validity from 01/03/2005 to 01/03/2010.**



Organisation pour l'Agrément Technique Européen  
European Organisation for Technical Approvals

## I LEGAL BASES AND GENERAL CONDITIONS

1. This European Technical Approval is issued by the Centre Scientifique et Technique du Bâtiment in accordance with:
  - Council Directive 89/106/EEC of 21 December 1988 on the approximation of laws, regulations and administrative provisions of Member States relating to construction products<sup>1</sup>, modified by the Council Directive 93/68/EEC of 22 July 1993<sup>2</sup>;
  - Décret n° 92-647 du 8 juillet 1992<sup>3</sup> concernant l'aptitude à l'usage des produits de construction;
  - Common Procedural Rules for Requesting, Preparing and the Granting of European Technical Approvals set out in the Annex of Commission Decision 94/23/EC<sup>4</sup>;
  - Guideline for European Technical Approval of « Metal Anchors for use in Concrete » ETAG 001, edition 1997, Part 1 « Anchors in general » and Part 2 « Torque-controlled expansion anchors ».
2. The Centre Scientifique et Technique du Bâtiment is authorised to check whether the provisions of this European Technical Approval are met. Checking may take place in the manufacturing plant (for example concerning the fulfilment of assumptions made in this European Technical Approval with regard to manufacturing). Nevertheless, the responsibility for the conformity of the products with the European Technical Approval and for their fitness for the intended use remains with the holder of the European Technical Approval.
3. This European Technical Approval is not to be transferred to manufacturers or agents of manufacturer other than those indicated on page 1; or manufacturing plants other than those indicated on page 1 of this European Technical Approval.
4. This European Technical Approval may be withdrawn by the Centre Scientifique et Technique du Bâtiment pursuant to Article 5 (1) of the Council Directive 89/106/EEC.
5. Reproduction of this European Technical Approval including transmission by electronic means shall be in full. However, partial reproduction can be made with the written consent of the Centre Scientifique et Technique du Bâtiment. In this case partial reproduction has to be designated as such. Texts and drawings of advertising brochures shall not contradict or misuse the European Technical Approval.
6. The European Technical Approval is issued by the approval body in its official language. This version corresponds to the version circulated within EOTA. Translations into other languages have to be designated as such.

---

<sup>1</sup> Official Journal of the European Communities n° L 40, 11.2.1989, p. 12

<sup>2</sup> Official Journal of the European Communities n° L 220, 30.8.1993, p. 1

<sup>3</sup> Journal officiel de la République française du 14 juillet 1992

<sup>4</sup> Official Journal of the European Communities n° L 17, 20.1.1994, p. 34

## **II SPECIFIC CONDITIONS OF THE EUROPEAN TECHNICAL APPROVAL**

### **1 Definition of product and intended use**

#### **1.1. Definition of product**

The Simpson Strong-Tie® Liebig Superplus™ A4 undercutting anchor in the sizes of M8, M12 and M16 is an anchor made of stainless steel, which is placed into a drilled hole and anchored by torque-controlled expansion.

For the installed anchor see figure given in Annex 1.

#### **1.2. Intended use**

The anchor is intended to be used for anchorages for which requirements for mechanical resistance and stability and safety in use in the sense of the Essential Requirements 1 and 4 of Council Directive 89/106/EEC shall be fulfilled and failure of anchorages made with these products would compromise the stability of the works, cause risk to human life and/or lead to considerable economic consequences. The anchor is to be used only for anchorages subject to static or quasi-static loading in reinforced or unreinforced normal weight concrete of strength classes C 20/25 minimum to C50/60 maximum according to ENV 206: 2000-12. It may be anchored in cracked or non-cracked concrete.

The anchor may be used in concrete subject to dry internal conditions and also in concrete subject to external atmospheric exposure (including industrial and marine environment), or exposure in permanently damp internal conditions, if no particular aggressive conditions exist. Such particular aggressive conditions are e.g. permanent, alternating immersion in seawater or the splash zone of seawater, chloride atmosphere of indoor swimming pools or atmosphere with extreme chemical pollution (e.g. in desulphurization plants or road tunnels where de-icing materials are used).

The provisions made in this European Technical Approval are based on an assumed intended working life of the anchor of 50 years. The indications given on the working life cannot be interpreted as a guarantee given by the producer, but are to be regarded only as a means for choosing the right products in relation to the expected economically reasonable working life of the works.

### **2 Characteristics of product and methods of verification**

#### **2.1. Characteristics of product**

The anchor in the sizes of M8, M12 and M16 corresponds to the drawings and provisions given in Annexes 1 to 4. The characteristic material values, dimensions and tolerances of the anchor not indicated in Annexes 2 and 3 shall correspond to the respective values laid down in the technical documentation<sup>5</sup> of this European Technical Approval. The characteristic anchor values for the design of anchorages are given in Annexes 4 to 11.

Each anchor is marked with the company label and the nominal diameter of the anchor on the distance sleeve. The marking is composed of a knurl or a groove corresponding to the setting

---

<sup>5</sup> The technical documentation of this European Technical Approval is deposited at the Centre Scientifique et Technique du Bâtiment and, as far as relevant for the tasks of the approved bodies involved in the attestation of conformity procedure, is handed over to the approved bodies.

depth mark as well as the product logo the anchor type SP, the bolt diameter, the hole diameter, the embedment depth, the thickness of the connected part and A4 for stainless steel. According to Annex 1.

The anchor shall only be packaged and supplied as a complete unit.

In order to distinguish the different embedment depths after setting, a dot is embossed on the nut or alternatively on the top of the anchor's head for the bigger embedment depth of each size.

## **2.2. Methods of verification**

The assessment of fitness of the anchor for the intended use in relation to the requirements for mechanical resistance and stability and safety in use in the sense of the Essential Requirements 1 and 4 has been made in accordance with the « Guideline for European Technical Approval of Metal Anchors for use in Concrete », Part 1 « Anchors in general » and Part 2 « Torque controlled expansion anchors», on the basis of Option 1.

## **3 Evaluation of Conformity and CE marking**

### **3.1. Attestation of conformity system**

The system of attestation of conformity 2 (i) (referred to as system 1) according to Council Directive 89/106/EEC Annex III laid down by the European Commission provides:

a) tasks for the manufacturer:

1. factory production control,
2. further testing of samples taken at the factory by the manufacturer in accordance with a prescribed test plan.

b) tasks for the approved body:

3. initial type-testing of the product,
4. initial inspection of factory and of factory production control,
5. continuous surveillance, assessment and approval of factory production control.

### **3.2. Responsibilities**

#### **3.2.1. Tasks of the manufacturer, factory production control**

The manufacturer has a factory production control system in the plant and exercises permanent internal control of production. All the elements, requirements and provisions adopted by the manufacturer are documented in a systematic manner in the form of written policies and procedures. This production control system ensures that the product is in conformity with the European Technical Approval.

The manufacturer shall only use raw materials supplied with the relevant inspection documents as laid down in the prescribed test plan<sup>6</sup>. The incoming raw materials shall be subject to controls and tests by the manufacturer before acceptance. Check of incoming materials such as

---

<sup>6</sup> The prescribed test plan has been deposited at the Centre Scientifique et Technique du Bâtiment and is only made available to the approved bodies involved in the conformity attestation procedure.

nuts, washers, wire for bolts and metal band for expansion sleeves shall include control of the inspection documents presented by suppliers (comparison with nominal values) by verifying dimension and determining material properties, e.g. tensile strength, hardness, surface finish.

The manufactured components of the anchor shall be subjected to the following tests:

- Dimensions of components:  
Threaded rod (total length), distance sleeve (length, outer diameter, thickness), threaded cone (length, diameter, angle), expansion sleeve (length, outer and inner diameter), washer (thickness).
- Material properties: yielding and ultimate tensile strength and hardness
- Visual control of correct assembly and of completeness of the anchor.
- Functioning of the thread of the final bolt.

The frequency of controls and tests conducted during production and on the assembled anchor is laid down in the prescribed test plan taking account of the automated manufacturing process of the anchor.

The results of factory production control are recorded and evaluated. The records include at least the following information:

- designation of the product, basic material and components;
- type of control or testing;
- date of manufacture of the product and date of testing of the product or basic material and components;
- result of control and testing and, if appropriate, comparison with requirements;
- signature of person responsible for factory production control.

The records shall be presented to the inspection body during the continuous surveillance. On request, they shall be presented to the Centre Scientifique et Technique du Bâtiment.

Details of the extent, nature and frequency of testing and controls to be performed within the factory production control shall correspond to the prescribed test plan which is part of the technical documentation of this European Technical Approval.

### 3.2.2. Tasks of approved bodies

#### 3.2.2.1. Initial type-testing of the product

For initial type-testing the results of the tests performed as part of the assessment for the European Technical Approval shall be used unless there are changes in the production line or plant. In such cases the necessary initial type-testing has to be agreed between the Centre Scientifique et Technique du Bâtiment and the approved bodies involved.

#### 3.2.2.2. Initial inspection of factory and of factory production control

The approved body shall ascertain that, in accordance with the prescribed test plan, the factory and the factory production control are suitable to ensure continuous and orderly manufacturing of the anchor according to the specifications mentioned in 2.1. as well as to the Annexes to the European Technical Approval.

### 3.2.2.3. Continuous surveillance

The approved body shall visit the factory at least once a year for regular inspection. It has to be verified that the system of factory production control and the specified automated manufacturing process are maintained taking account of the prescribed test plan.

Continuous surveillance and assessment of factory production control have to be performed according to the prescribed test plan.

The results of product certification and continuous surveillance shall be made available on demand by the certification body or inspection body, respectively, to the Centre Scientifique et Technique du Bâtiment. In cases where the provisions of the European Technical Approval and the prescribed test plan are no longer fulfilled the conformity certificate shall be withdrawn.

### 3.3. CE-Marking

The CE marking shall be affixed on each packaging of anchors. The symbol « CE » shall be accompanied by the following information:

- identification number of the certification body;
- name or identifying mark of the producer and manufacturing plant;
- the last two digits of the year in which the CE-marking was affixed;
- number of the EC certificate of conformity;
- number of the European Technical Approval;
- use category (ETAG 001-1 Option 1);
- size.

## 4 Assumptions under which the fitness of the product for the intended use was favourably assessed

### 4.1. Manufacturing

The anchor is manufactured in accordance with the provisions of the European Technical Approval using the automated manufacturing process as identified during inspection of the plant by the Centre Scientifique et Technique du Bâtiment and the approved body and laid down in the technical documentation.

### 4.2. Installation

#### 4.2.1. Design of anchorages

The fitness of the anchors for the intended use is given under the following conditions:

The anchorages are designed in accordance with the « Guideline for European Technical Approval of Metal Anchors for Use in Concrete », Annex C, Method A, for torque-controlled expansion anchors under the responsibility of an engineer experienced in anchorages and concrete work.

Verifiable calculation notes and drawings are prepared taking account of the loads to be anchored. The position of the anchor is indicated on the design drawings (e.g. position of the anchor relative to reinforcement or to support, etc.).

#### 4.2.2. Installation of anchors

The fitness for use of the anchor can only be assumed if the anchor is installed as follows:

- anchor installation carried out by appropriately qualified personnel and under the supervision of the person responsible for technical matters on the site;
- use of the anchor only as supplied by the manufacturer without exchanging the components of an anchor;
- anchor installation in accordance with the manufacturer's specifications and drawings prepared for that purpose and using the appropriate special tools;
- thickness of the fixture corresponding to the range of required thickness values for the type of anchor;
- checks before placing the anchor to ensure that the strength class of the concrete in which the anchor is to be placed is in the range given and is not lower than that of the concrete to which the characteristic loads apply;
- check of concrete being well compacted, e.g. without significant voids;
- clearing the hole of drilling dust;
- anchor installation ensuring the specified embedment depth, that is the appropriate depth marking of the anchor not exceeding the concrete surface or embedment depth control;
- keeping of the edge distance and spacing to the specified values without minus tolerances;
- positioning of the drill holes without damaging the reinforcement;
- in case of aborted hole: new drilling at a minimum distance away of twice the depth of the aborted hole or smaller distance if the aborted drill hole is filled with high strength mortar and if under shear or oblique tension load it is not to the anchor in the direction of load application;
- application of the torque moment given in Annex 4 using a calibrated torque wrench.

#### 4.2.3. Responsibility of the manufacturer

It is the manufacturer's responsibility to ensure that the information on the specific conditions according to 1 and 2 including Annexes referred to in 4.2.1. and 4.2.2. is given to those who are concerned. This information may be made by reproduction of the respective parts of the European Technical Approval. In addition all installation data shall be shown clearly on the package and/or on an enclosed instruction sheet, preferably using illustration(s).

The minimum data required are:

- drill bit diameter,
- thread diameter,
- maximum thickness of the fixture,
- minimum installation depth,
- minimum hole depth,
- required torque moment,
- information on the installation procedure, including cleaning of the hole, preferably by means of an illustration,
- reference to any special installation equipment needed,

identification of the manufacturing batch. All data shall be presented in a clear and explicit form.

**The original French version is  
signed by**

**Le Directeur Technique  
C. BALOCHE**

**Simpson Strong-Tie®  
Liebig Superplus™ A4 self-undercutting anchor**

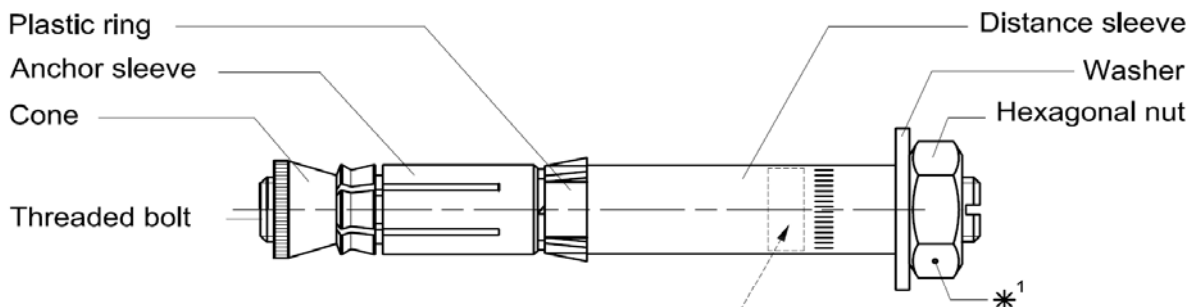

**Marking:**

Identifying mark:	⊗ or ≠
Anchor identity:	for example: SP M8 14/40/15
Setting depth marking:	knurl or groove
Category:	A4
* <sup>1</sup> - Setting depth identification:	Embossed dot for higher depth per size (alternatively on top of threaded rod)

**Simpson Strong-Tie®  
Liebig Superplus™ A4 self-undercutting anchor after installation**

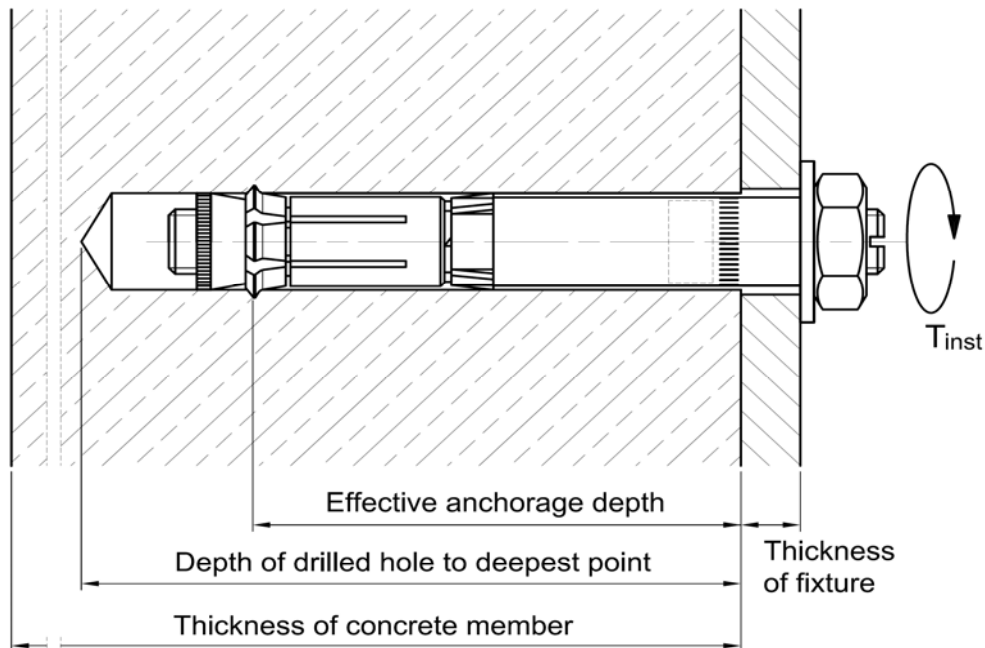

**Simpson Strong-Tie®  
Liebig Superplus™ A4 self-undercutting anchor**

Product and intended use

**Annex 1**

of European  
Technical Approval  
**ETA-05/0013**

**Simpson Strong-Tie®**  
**Liebig Superplus™ A4 self-undercutting anchor**

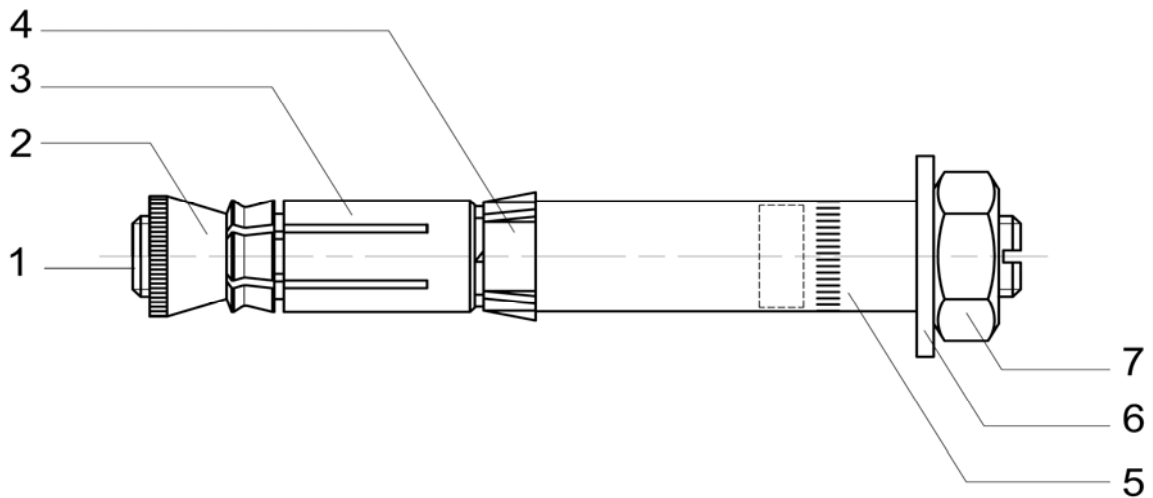

**Table 1: Materials**

Part	Designation	Material:
1	Threaded bolt	EN 10088: 1.4401 / 1.4404 / 1.4571 EN ISO 3506-1: A4-80
2	Cone	EN 10088: 1.4401 / 1.4404 / 1.4571
3	Anchor sleeve	EN 10088: 1.4401 / 1.4404 / 1.4571
4	Plastic ring	PE
5	Distance sleeve	EN 10088: 1.4401 / 1.4404 / 1.4571
6	Washer	EN 10088: 1.4401 / 1.4404 / 1.4571
7	Hexagonal nut	EN 10088: 1.4401 / 1.4404 / 1.4571 EN ISO 3506-2: A4-80

**Simpson Strong-Tie®**  
**Liebig Superplus™ A4 self-undercutting anchor**

**Materials**

**Annex 2**

of European  
 Technical Approval  
**ETA-05/0013**

Simpson Strong-Tie®

Liebig Superplus™ A4 self-undercutting anchor

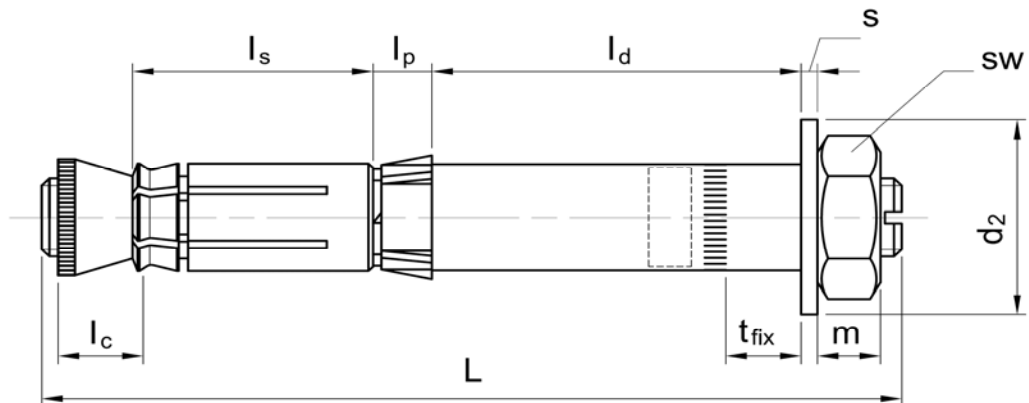

Table 2: Dimensions of the anchor

Anchor type	Main dimensions		Cone $l_c$ [mm]	Anchor sleeve $l_s$ [mm]	Plastic ring $l_p$ [mm]	Distance sleeve $l_d$ [mm]	Washer			Hexagonal nut	
	$t_{fix}$ [mm]	L [mm]					s [mm]	$d_2$ [mm]	$d_1$ [mm]	m [mm]	SW [mm]
BLS M8 - 14/40/..	0-100	65-165	11.8	26	6.0	9-109	1.5	20	8.4	6.5	17
BLS M8 - 14/80/..	0-150	105-255	11.8	26	6.0	49-199	1.5	20	8.4	6.5	17
BLS M12 - 20/80/..	0-200	115-315	16.5	40	11.5	30-230	3.5	30	13.0	10.0	22
BLS M12 - 20/150/..	0-250	185-435	16.5	40	11.5	100-350	3.5	30	13.0	10.0	22
BLS M16 - 25/150/..	0-250	190-440	17.8	60	11.5	80-330	4.0	40	17.0	13.0	27
BLS M16 - 25/200/..	0-300	240-540	17.8	60	11.5	130-430	4.0	40	17.0	13.0	27

Simpson Strong-Tie®  
Liebig Superplus™ A4 self-undercutting anchor

Dimensions of the anchor

**Annex 3**

of European  
Technical Approval  
**ETA-05/0013**

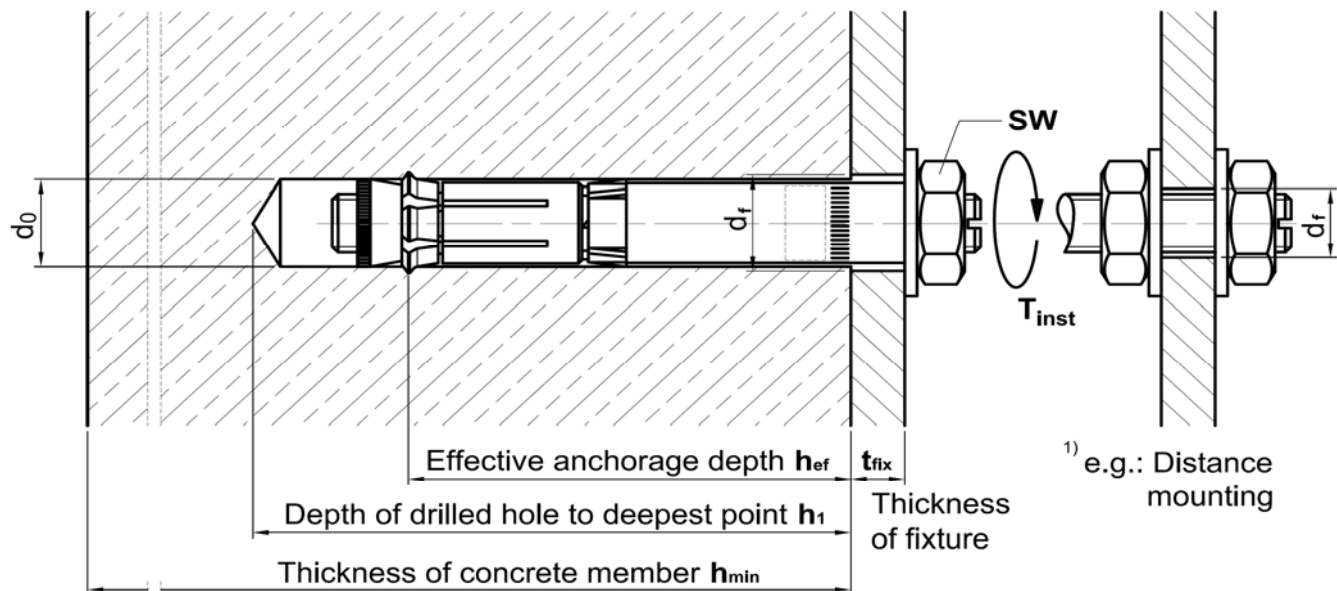

**Table 3: Installation data**

Liebig Superplus™ A4			Anchor type					
			BLS M8 - 14		BLS M12 - 20		BLS M16 - 25	
			/40/..	/80/..	/80/..	/150/..	/150/..	/200/..
Drill hole diameter	$d_o$	[mm]	14		20		25	
Cutting diameter at the upper tolerance limit (maximum diameter bit)	$d_{cut,max} \leq$	[mm]	14.50		20.55		25.55	
Depth of drilled hole to deepest point	$h_1 \geq$	[mm]	60	100	105	175	185	235
Effective anchorage depth	$h_{ef} \geq$	[mm]	40	80	80	150	150	200
Diameter of clearance hole in the fixture	In-place anchorage	$d_f \leq$	16		21		26	
	Mounting on the threaded bolt <sup>1)</sup>	$d_f \leq$	10		14		18	
Thickness of fixture	$t_{fix}$	[mm]	0-100	0-150	0-200	0-250	0-250	0-300
Width across flats	SW	[mm]	17		22		27	
Torque moment	$T_{inst}$	[Nm]	25		80		180	

**Table 4: Minimum thickness of concrete member, center spacing and edge distance**

Liebig Superplus™ A4			Anchor type					
			BLS M8 - 14		BLS M12 - 20		BLS M16 - 25	
			/40/..	/80/..	/80/..	/150/..	/150/..	/200/..
Minimum thickness of concrete member	$h_{min}$	[mm]	100	160	160	300	300	400
Minimum allowable spacing	$s_{min}$	[mm]	80	80	150	150	150	180
Minimum allowable edge distance	$c_{min}$	[mm]	60	50	100	80	100	100

**Table 5: Characteristic values of resistance to tensile loads and partial safety factors for material according to design method A**

Liebig Superplus™ A4			Anchor type					
			BLS M8 - 14		BLS M12 - 20		BLS M16 - 25	
			/40/..	/80/..	/80/..	/150/..	/150/..	/200/..
<b>Steel failure</b>								
Characteristic resistance	$N_{Rk,s}$	[kN]	29.3		67.4		125.6	
Partial safety factor	$\gamma_{Ms}$	[-]	1.6 <sup>1)</sup>					
<b>Pull-out failure</b>								
Characteristic resistance in cracked concrete C20/25	$N_{Rk,p}$	[kN]	9	12	25	40	60	60
Characteristic resistance in non-cracked concrete C20/25	$N_{Rk,p}$	[kN]	not decisive failure mode					
Increasing factor for $N_{Rk,p}$	$\Psi_C$	C30/37	1.22					
		C40/50	1.41					
		C50/60	1.55					
Partial safety factor	$\gamma_{Mp}$	[-]	1.5 <sup>1)</sup>					
<b>Concrete cone failure and splitting failure</b>								
Characteristic resistance in cracked concrete C20/25	$N^0_{Rk,c}$ <sup>2)</sup>	[kN]	9.1	25.8	25.8	66.1	66.1	101.8
Characteristic resistance in non-cracked concrete C20/25	$N^0_{Rk,c}$ <sup>2)</sup>	[kN]	12.8	36.1	36.1	92.6	92.6	142.5
Increasing factor for $N^0_{Rk,c}$	$\Psi_C$	C30/37	1.22					
		C40/50	1.41					
		C50/60	1.55					
Effective anchorage depth	$h_{ef}$	[mm]	40	80	80	150	150	200
Center Spacing	$s_{cr,N}$	[mm]	120	240	240	450	450	600
Edge distance	$c_{cr,N}$	[mm]	60	120	120	225	225	300
Center Spacing ( splitting )	$s_{cr,sp}$	[mm]	140	360	360	540	560	560
Edge distance ( splitting )	$c_{cr,sp}$	[mm]	70	180	180	270	280	280
Partial safety factor	$\gamma_{Mc} = \gamma_{Msp}$	[-]	1.5 <sup>1)</sup>					

<sup>1)</sup> In absence of other national regulations

<sup>2)</sup> Characteristic resistance values for the evaluation of one single anchor without influence of spacings ( $s \geq s_{cr,N}$ ) or edge distances ( $c \geq c_{cr,N}$ ). For evaluation of groups of anchors ( $s < s_{cr,N}$ ) or anchors close to edges ( $c < c_{cr,N}$ ), equation (5.2) of ETAG 001, part C has to be taken into account.

Simpson Strong-Tie®  
Liebig Superplus™ A4 self-undercutting anchor

Design method A:  
Characteristic values of resistance to tensile loads

**Annex 5**

of European  
Technical Approval  
**ETA-05/0013**

**Table 6: Displacements under tensile loads**

Anchor type	Displacements and tensile loads in C20/25 to C50/60											
	Cracked concrete						Non-cracked concrete					
	C20/25			C50/60			C20/25			C50/60		
	N [kN]	$\delta_{N0}$ [mm]	$\delta_{N\infty}$ [mm]	N [kN]	$\delta_{N0}$ [mm]	$\delta_{N\infty}$ [mm]	N [kN]	$\delta_{N0}$ [mm]	$\delta_{N\infty}$ [mm]	N [kN]	$\delta_{N0}$ [mm]	$\delta_{N\infty}$ [mm]
BLS M8 - 14/40/..	3.6	0.3	1.1	5.5	0.3	1.1	3.4	0.2	0.6	5.5	0.1	0.6
BLS M8 - 14/80/..	5.7	0.5	1.7	5.7	0.5	1.7	13.9	2.0	2.0	13.9	2.0	2.0
BLS M12 - 20/80/..	9.9	0.5	0.9	15.4	0.7	0.9	14.3	0.4	0.6	32.1	1.0	1.0
BLS M12 - 20/150/..	15.9	0.9	1.4	15.4	0.7	1.4	32.1	3.8	3.8	32.1	1.0	1.0
BLS M16 - 25/150/..	23.8	0.9	1.4	36.9	1.4	1.4	36.7	0.7	0.7	59.8	3.4	3.4
BLS M16 - 25/200/..	23.8	1.2	1.6	36.9	1.4	1.6	59.8	5.0	5.0	59.8	3.4	3.4

**Simpson Strong-Tie®**  
**Liebig Superplus™ A4 self-undercutting anchor**

**Design method A:**  
**Displacements under tensile loads**

**Annex 6**

of European  
 Technical Approval  
**ETA-05/0013**

**Table 7: Characteristic values of resistance to shear loads and partial safety factors for material according to design method A**

Liebig Superplus™ A4			Anchor type					
			BLS M8 - 14		BLS M12 - 20		BLS M16 - 25	
			/40/..	/80/..	/80/..	/150/..	/150/..	/200/..
<b>Steel failure without lever arm</b>								
Characteristic resistance for In-place anchorage	$V_{Rk,s}$	[kN]	44.6		90.3		168.9	
Partial safety factor	$\gamma_{Ms}$	[-]	1.33 <sup>1)</sup>					
<b>Steel failure with lever arm</b>								
Characteristic bending resistance	$M_{Rk,s}^0$	[Nm]	30		105		266	
Partial safety factor	$\gamma_{Ms}$	[-]	1.33 <sup>1)</sup>					
<b>Concrete pryout failure</b>								
Factor in equation ( 5.6 ) of ETAG Annex C, § 5.2.3.3	k	[-]	1	2	2		2	
Partial safety factor	$\gamma_{Mc}$	[-]	1.5 <sup>1)</sup>					
<b>Concrete edge failure</b>								
Effective length of anchor under shear load	$l_f$	[mm]	40	80	80	150	150	200
Outside diameter of anchor	$d_{nom}$	[mm]	14		20		25	
<b>Cracked concrete</b> without any edge reinforcement	$\Psi_{ucr,V}$	[-]	1.00					
<b>Cracked concrete</b> with straight edge reinforcement > Ø12 mm			1.20					
<b>Cracked concrete</b> with edge reinforcement and closely spaced stirrups ( $a \leq 100$ mm) or <b>non cracked concrete</b>			1.40					
Partial safety factor	$\gamma_{Mc}$	[-]	1.5 <sup>1)</sup>					

<sup>1)</sup> In absence of other national regulations

Simpson Strong-Tie®  
Liebig Superplus™ A4 self-undercutting anchor

Design method A:  
Characteristic values of resistance to shear loads

**Annex 7**

of European  
Technical Approval  
**ETA-05/0013**

**Table 8: Displacements under shear loads**

Anchor type	Displacements and shear loads in C20/25 to C50/60					
	Cracked concrete			Non-cracked concrete		
	C20/25 - C50/60			C20/25 - C50/60		
	V	$\delta_{V0}$	$\delta_{V\infty}$	V	$\delta_{V0}$	$\delta_{V\infty}$
	[kN]	[mm]	[mm]	[kN]	[mm]	[mm]
<b>BLS M8 - 14/40/..</b>	25.5	6.3 (+1.7)	9.5 (+1.7)	25.5	6.3 (+1.7)	9.5 (+1.7)
<b>BLS M8 - 14/80/..</b>	25.5	6.3 (+1.7)	9.5 (+1.7)	25.5	6.3 (+1.7)	9.5 (+1.7)
<b>BLS M12 - 20/80/..</b>	51.6	8.0 (+1.7)	12.0 (+1.7)	51.6	8.0 (+1.7)	12.0 (+1.7)
<b>BLS M12 - 20/150/..</b>	51.6	8.0 (+1.7)	12.0 (+1.7)	51.6	8.0 (+1.7)	12.0 (+1.7)
<b>BLS M16 - 25/150/..</b>	96.5	8.8 (+1.7)	13.2 (+1.7)	96.5	8.8 (+1.7)	13.2 (+1.7)
<b>BLS M16 - 25/200/..</b>	96.5	8.8 (+1.7)	13.2 (+1.7)	96.5	8.8 (+1.7)	13.2 (+1.7)

( ) : Values indicate the additional displacement caused by the movement between the anchor's body and the hole in the concrete or the hole in the fixture.

**Simpson Strong-Tie®**  
**Liebig Superplus™ A4 self-undercutting anchor**

**Design method A:**  
**Displacement under shear loads**

**Annex 8**

of European  
 Technical Approval  
**ETA-05/0013**

**Table 9: Characteristic tension resistance in cracked and non-cracked concrete C20/25 to C50/60 under fire exposure according to design method A**

Liebig Superplus™ A4		BLS M8 - 14/40/..				BLS M12 - 20/80/..				BLS M16 - 25/150/..			
Fire resistance duration	R... [min]	30	60	90	120	30	60	90	120	30	60	90	120
<b>Steel failure</b>													
Characteristic resistance	$N_{Rk,s,fi}$ [kN]	0.73	0.59	0.44	0.37	2.5	2.1	1.7	1.3	4.7	3.9	3.1	2.5
<b>Pull-out failure</b>													
Characteristic resistance	$N_{Rk,p,fi}$ [kN]	2.3		1.8		6.3		5.0		15.0		12.0	
<b>Concrete cone failure</b>													
Characteristic resistance	$N_{Rk,c,fi}^0$ [kN]	1.8		1.5		10.3		8.2		49.6		39.7	
Spacing	$s_{cr,N}$ [mm]	4 x $h_{ef}$											
	$s_{min}$ [mm]	80				150				150			
Edge distance	$c_{cr,N}$ [mm]	2 x $h_{ef}$											
	$c_{min}$ [mm]	Fire attack from one side:						$c_{min} = 2 \times h_{ef}$					
		Fire attack from more than one side:						$c_{min} \geq 300 \text{ mm and } \geq 2 \times h_{ef}$					

In absence of other national regulations the partial safety factor for resistance under fire exposure  $\gamma_{M,fi} = 1.0$  is recommended.

Design method A: Characteristic values of tension load resistance under fire exposure

Simpson Strong-Tie®  
 Liebig Superplus™ A4 self-undercutting anchor

Annex 9  
 of European  
 Technical Approval  
 ETA-05/0013

**Table 9: Characteristic tension resistance in cracked and non-cracked concrete C20/25 to C50/60 under fire exposure according to design method A**

Liebig Superplus™ A4		BLS M8 - 14/ 80/ ..				BLS M12 - 20/150/ ..				BLS M16 - 25/200/ ..			
Fire resistance duration	R... [min]	30	60	90	120	30	60	90	120	30	60	90	120
<b>Steel failure</b>													
Characteristic resistance	$N_{Rk,s,fi}$ [kN]	0.73	0.59	0.44	0.37	2.5	2.1	1.7	1.3	4.7	3.9	3.1	2.5
<b>Pull-out failure</b>													
Characteristic resistance	$N_{Rk,p,fi}$ [kN]	3.0		2.4		10.0		8.0		15.0		12.0	
<b>Concrete cone failure</b>													
Characteristic resistance	$N_{Rk,c,fi}^0$ [kN]	10.3		8.2		49.6		39.7		101.8		81.5	
Spacing	$s_{cr,N}$ [mm]	4 x $h_{ef}$											
	$s_{min}$ [mm]	80				150				180			
Edge distance	$c_{cr,N}$ [mm]	2 x $h_{ef}$											
	$c_{min}$ [mm]	Fire attack from one side:						$c_{min} = 2 \times h_{ef}$					
		Fire attack from more than one side:						$c_{min} \geq 300 \text{ mm and } \geq 2 \times h_{ef}$					

In absence of other national regulations the partial safety factor for resistance under fire exposure  $\gamma_{M,fi} = 1.0$  is recommended.

Design method A: Characteristic values of tension load resistance under fire exposure

Simpson Strong-Tie®  
 Liebig Superplus™ A4 self-undercutting anchor

Annex 10  
 of European  
 Technical Approval  
 ETA-05/0013

**Table 10: Characteristic shear resistance in cracked and non-cracked concrete C20/25 to C50/60 under fire exposure according to design method A**

Liebig Superplus™ A4		BLS M8				BLS M12				BLS M16			
Fire resistance duration	R... [min]	30	60	90	120	30	60	90	120	30	60	90	120
<b>Steel failure without lever arm</b>													
Characteristic resistance	$V_{Rk,s,fi}$ [kN]	0.73	0.59	0.44	0.37	2.5	2.1	1.7	1.3	4.7	3.9	3.1	2.5
<b>Steel failure with lever arm</b>													
Characteristic bending moment	$M^0_{Rk,s,fi}$ [Nm]	0.75	0.60	0.45	0.38	3.9	3.3	2.6	2.1	9.9	8.3	6.6	5.3
<b>Concrete pry-out failure</b>		<b>BLS M8 - 14/40/..</b>				<b>BLS M12 - 20/80/..</b>				<b>BLS M16 - 25/150/..</b>			
Factor in equation (5.6) of ETAG 001 Annex C, 5.2.3.3	k [-]	1				2							
Characteristic resistance	$V^0_{Rk,cp,fi}$ [kN]	1.8		1.5		20.6		16.4		99.2		79.4	
<b>Concrete pry-out failure</b>		<b>BLS M8 - 14/80/..</b>				<b>BLS M12 - 20/150/..</b>				<b>BLS M16 - 25/200/..</b>			
Factor in equation (5.6) of ETAG 001 Annex C, 5.2.3.3	k [-]	2											
Characteristic resistance	$V^0_{Rk,cp,fi}$ [kN]	20.6		16.4		99.2		79.4		203.6		163.0	
<b>Concrete edge failure</b>													
The initial value $V^0_{Rk,c,fi}$ of the characteristic resistance in concrete C20/25 to C50/60 under fire exposure is determined by: $V^0_{Rk,c,fi} = 0,25 \times V^0_{Rk,c}$ ( $\leq R90$ ) $V^0_{Rk,c,fi} = 0,20 \times V^0_{Rk,c}$ (R120) with $V^0_{Rk,c}$ initial value of the characteristic resistance in cracked concrete C20/25 under normal temperature.													

In absence of other national regulations the partial safety factor for resistance under fire exposure  $\gamma_{M,fi} = 1.0$  is recommended.

Design method A: Characteristic values of shear load resistance under fire exposure  
 Simpson Strong-Tie®  
 Liebig Superplus™ A4 self-undercutting anchor  
 Annex 11  
 of European Technical Approval  
 ETA-05/0013